

PRECISION MACHINE VISION LENS

KV1614SS

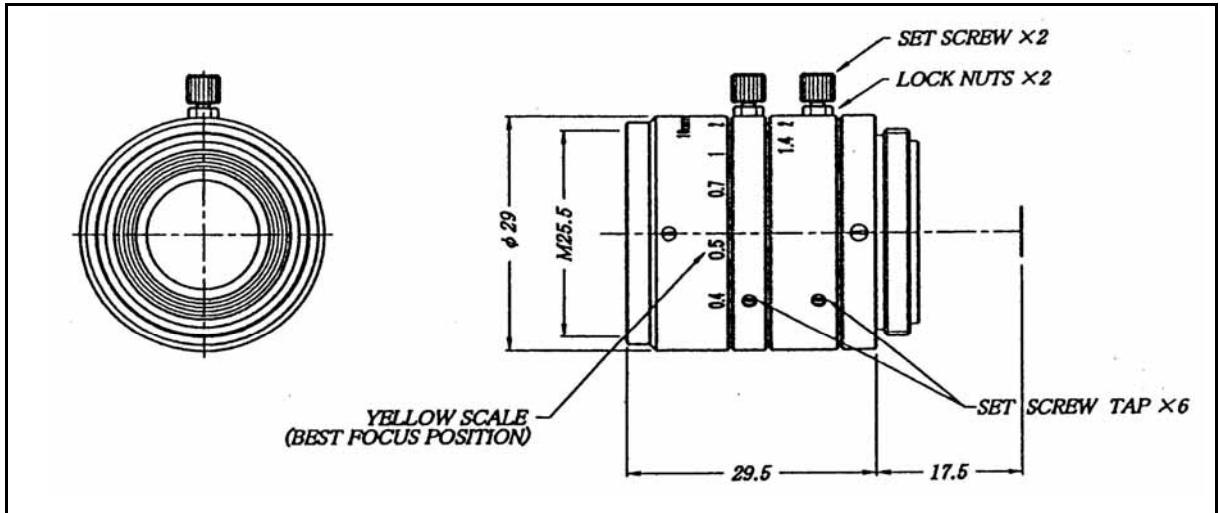

Image Format:	2/3-inch
Focal Length:	16mm
Relative Aperture:	F = 1 : 1.4
Iris Range:	1.4 - 16
Angular Field of View:	Horizontal: 30.75°
	Vertical: 23.31°
	Diagonal: 37.94°
Minimum Object Distance(MOD):	0.25m
View Area at Minimum Distance:	119.4 (H) x 89.6 (V)mm
Back Focus:	12.78mm
Flange Back:	17.5mm
Operation:	Focus: Manual with lock
	Iris: Manual with lock
Lens Mount:	C-Mount Type
Filter Screw:	25.5mm, P = 0.5
Dimensions:	φ29 x 29.5mm
Weight:	42g
TV Distortion:	On 2/3" CCD: -0.28%