

PRECISION MACHINE VISION LENS

KV2514SS

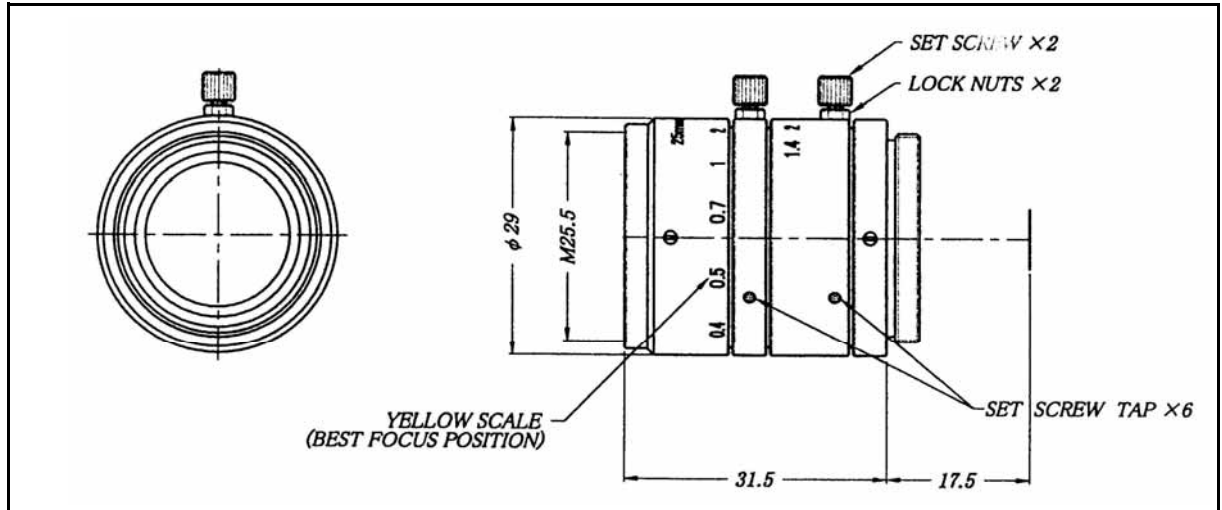

Image Format:	2/3-inch
Focal Length:	25mm
Relative Aperture:	F = 1: 1.4
Iris Range:	1.4 - 16
Angular Field of View:	Horizontal: 20.1° Vertical: 15.1° Diagonal: 24.95°
Minimum Object Distance(MOD):	0.25m
View Area at Minimum Distance:	72.1 (H) x 54.1 (V)mm
Back Focus:	13.13mm
Flange Back:	17.5mm
Operation:	Focus: Manual with lock Iris: Manual with lock
Lens Mount:	C-Mount Type
Filter Screw:	25.5mm, P = 0.5
Dimensions:	φ29 x 31.5mm
Weight:	45g
TV Distortion:	On 2/3" CCD: -0.30%