

# PRECISION MACHINE VISION LENS

## KV3520SS

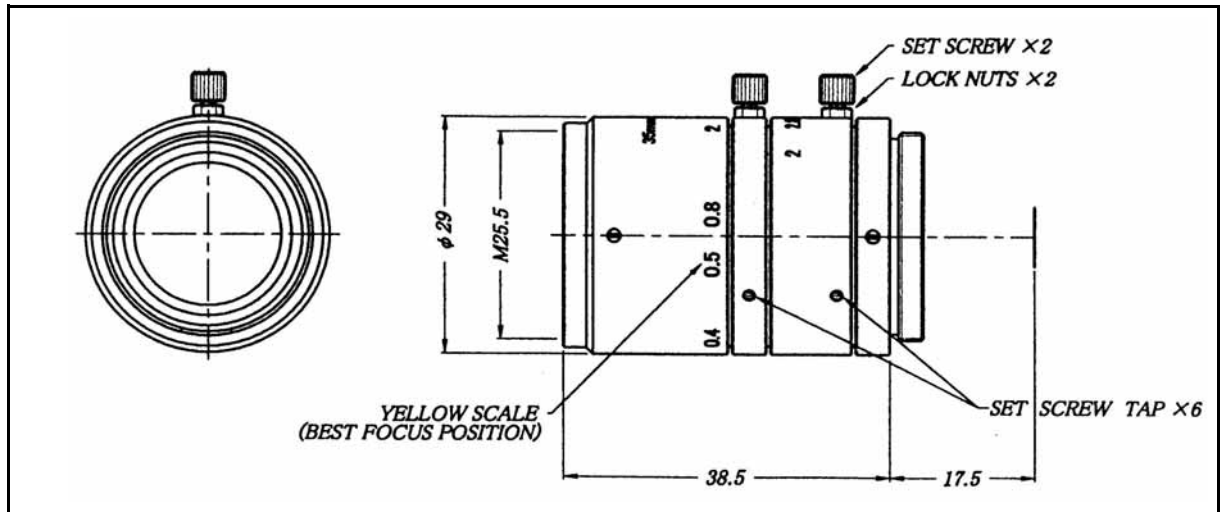

<b>Image Format:</b>	2/3-inch
<b>Focal Length:</b>	35mm
<b>Relative Aperture:</b>	F = 1: 2.0
<b>Iris Range:</b>	2.0 - 22
<b>Angular Field of View:</b>	<b>Horizontal:</b> 14.33°
	<b>Vertical:</b> 10.45°
	<b>Diagonal:</b> 17.86°
<b>Minimum Object Distance(MOD):</b>	0.25m
<b>View Area at Minimum Distance:</b>	46.2 (H) x 33.6 (V)mm
<b>Back Focus:</b>	18.06mm
<b>Flange Back:</b>	17.5mm
<b>Operation:</b>	<b>Focus:</b> Manual with lock
	<b>Iris:</b> Manual with lock
<b>Lens Mount:</b>	<b>C-Mount Type</b>
<b>Filter Screw:</b>	25.5mm, P = 0.5
<b>Dimensions:</b>	φ29 x 38.5mm
<b>Weight:</b>	55g
<b>TV Distortion:</b>	<b>On 2/3" CCD:</b> -0.02%