

PRECISION MACHINE VISION LENS

KV5028SS

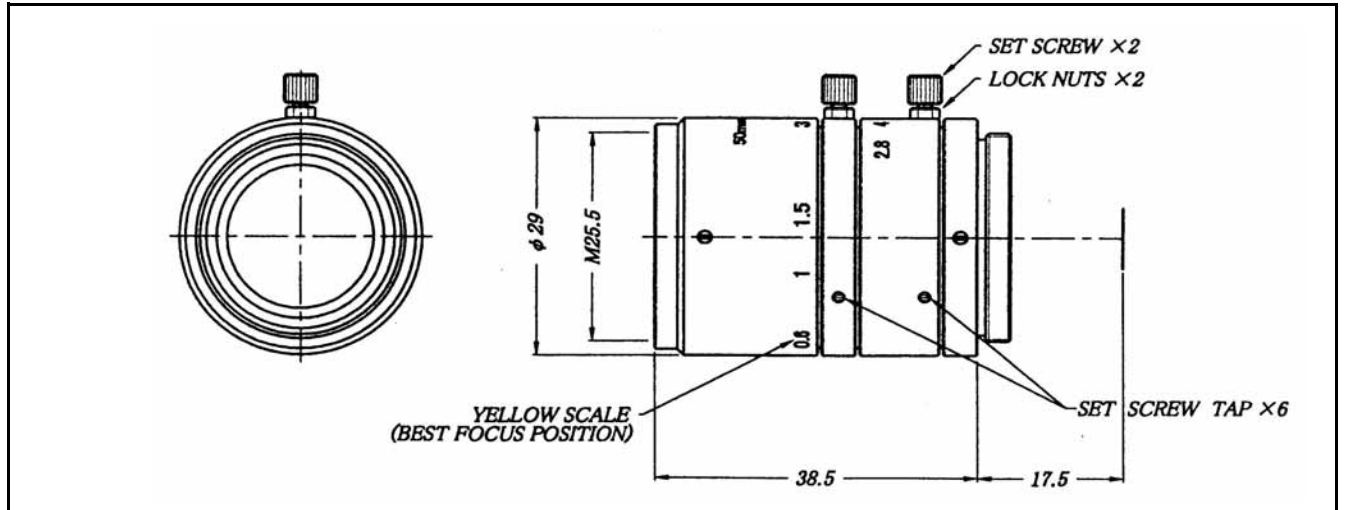

Image Format:	2/3-inch
Focal Length:	50mm
Relative Aperture:	F = 1: 2.8
Iris Range:	2.8 - 22
Angular Field of View:	Horizontal: 9.98°
	Vertical: 7.49°
	Diagonal: 12.46°
Minimum Object Distance(MOD):	0.5m
View Area at Minimum Distance:	68.1 (H) x 51.1 (V)mm
Back Focus:	21.2mm
Flange Back:	17.5mm
Operation:	Focus: Manual with lock
	Iris: Manual with lock
Lens Mount:	C-Mount Type
Filter Screw:	25.5mm, P = 0.5
Dimensions:	φ29 x 38.5mm
Weight:	55g
TV Distortion:	On 2/3" CCD: -0.20%