

PRECISION MACHINE VISION LENS

KV5028TS

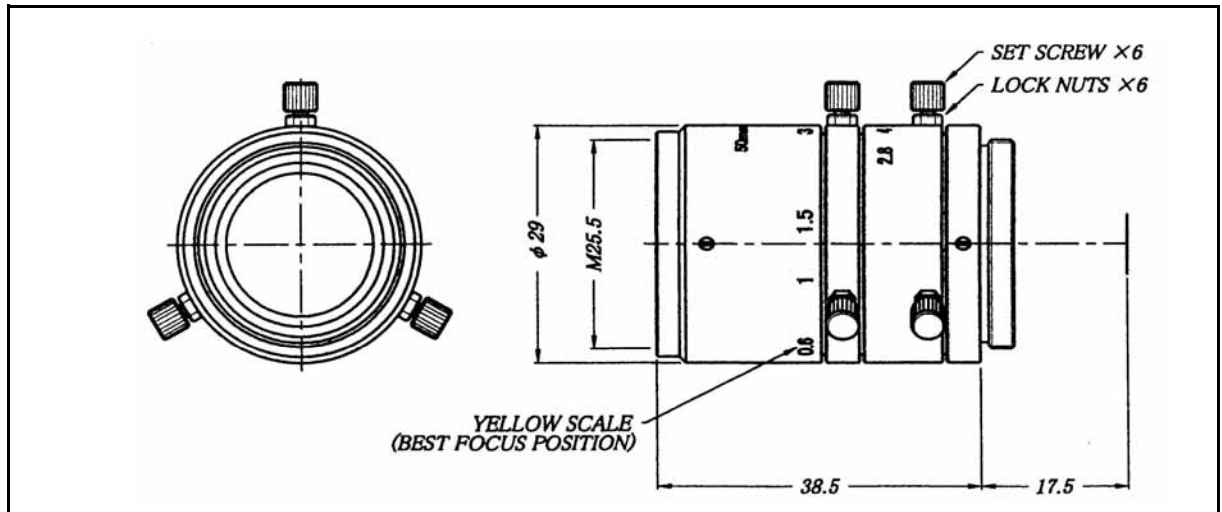

| | |
|---------------------------------------|--------------------------------|
| Image Format: | 2/3-inch |
| Focal Length: | 50mm |
| Relative Aperture: | F = 1: 2.8 |
| Iris Range: | 2.8 - 22 |
| Angular Field of View: | Horizontal: 9.98° |
| | Vertical: 7.49° |
| | Diagonal: 12.46° |
| Minimum Object Distance(MOD): | 0.5m |
| View Area at Minimum Distance: | 68.1 (H) x 51.1 (V)mm |
| Back Focus: | 21.2mm |
| Flange Back: | 17.5mm |
| Operation: | Focus: Manual with lock |
| | Iris: Manual with lock |
| Lens Mount: | C-Mount Type |
| Filter Screw: | 25.5mm, P = 0.5 |
| Dimensions: | φ29 x 38.5mm |
| Weight: | 55g |
| TV Distortion: | On 2/3" CCD: -0.20% |