

PRECISION MACHINE VISION LENS

MV1218TL

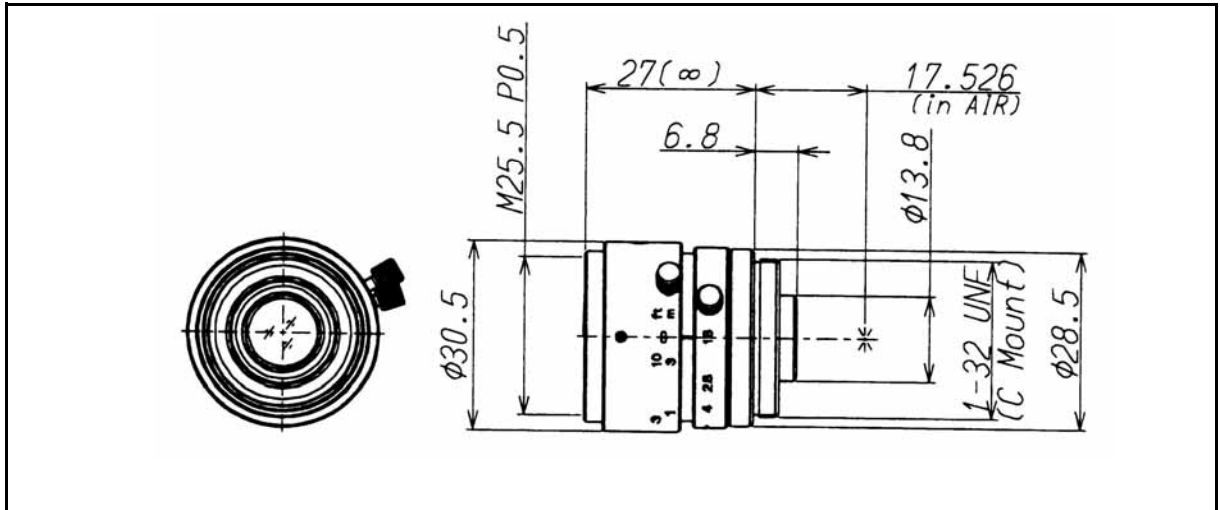

Image Format:	2/3-inch
Focal Length:	12mm
Relative Aperture:	F = 1: 1.8
Iris Range:	1.8 - 16
Angular Field of View:	Horizontal: 30.9° Vertical: 23.2°
Minimum Object Distance(MOD):	0.29m
Back Focus:	11.85mm
Flange Back:	17.526mm
Operation:	Focus: Manual with lock Iris: Manual with lock
Lens Mount:	C-Mount Type
Filter Screw:	25.5mm, P = 0.5
Dimensions:	φ30.5 x 27mm
Weight:	48g
Operating Temperature:	-5 ~ +50°C

Note : Angular of field of view (H x V) is on the 2/3-inch CCD sensor at MOD.