

PRECISION MACHINE VISION LENS

MV1614TL

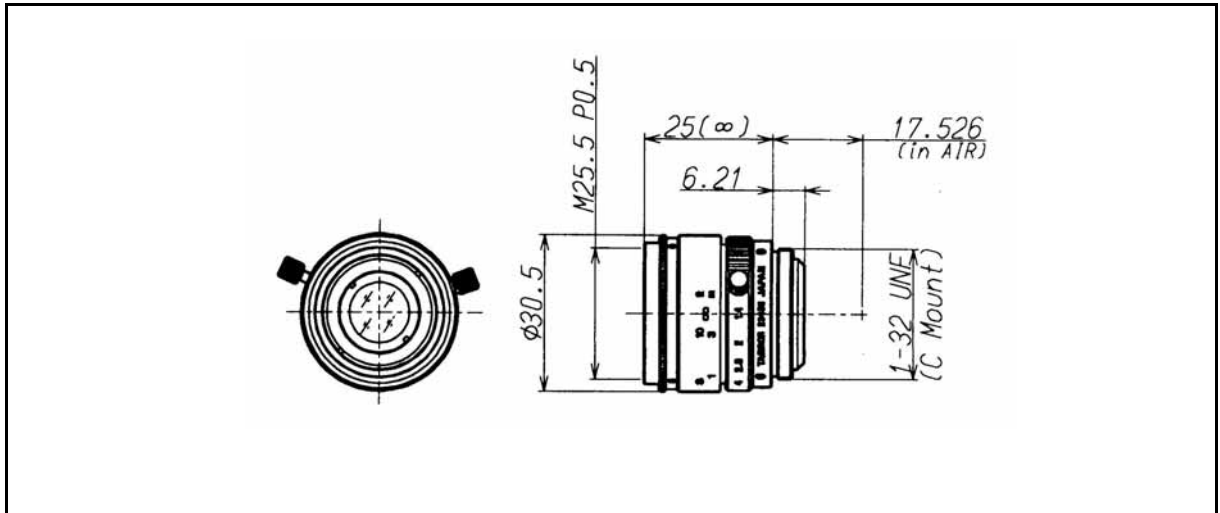

Image Format:	2/3-inch
Focal Length:	16mm
Relative Aperture:	F = 1.4
Iris Range:	1.4 - 16
Angular Field of View:	Horizontal: 30.90°
	Vertical: 23.20°
Minimum Object Distance(MOD):	0.3m
Back Focus:	11.85mm
Flange Back:	17.526mm
Operation:	Focus: Manual with lock
	Iris: Manual with lock
Lens Mount:	C-Mount Type
Filter Screw:	25.5mm, P = 0.5
Dimensions:	$\phi 30.5 \times 25\text{mm}$
Weight:	48g
Operating Temperature:	-5 ~ +50°C