

PRECISION MACHINE VISION LENS

LV0814

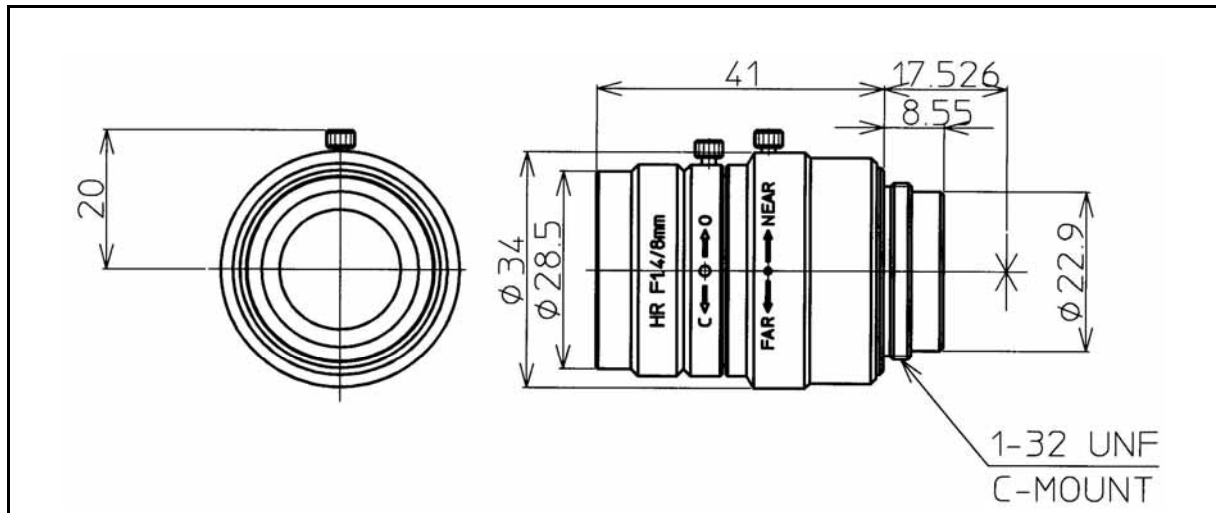

Image Format:	2/3-inch
Focal Length:	8mm
Relative Aperture:	F = 1: 1.4
Iris Range:	1.4 - 16
Angular Field of View:	Horizontal: 56.5°
	Vertical: 43.9°
Resolution:	Center : 100 lp/mm
	Corner : 80 lp/mm
Distortion:	on 2/3" sensor : -0.60%
	on 1/2" sensor : -0.30%
MOD (Minimum Object Distance):	0.1m
Exit Pupil:	-920mm
Back Focus:	9.5mm in air
Flange Back:	17.526mm
Operation:	Focus: Manual with lock screw
	Iris: Manual with lock screw
Lens Mount:	C-Mount Type
Filter Screw:	27mm, P = 0.5
Dimensions:	φ34 x 41mm
Weight:	83g
Operating Temperature:	-10 ~ +45°C

Note : Angular field of view (H x V) is captured on the 2/3-inch image sensor at MOD.