

PRECISION MACHINE VISION LENS

LV2514

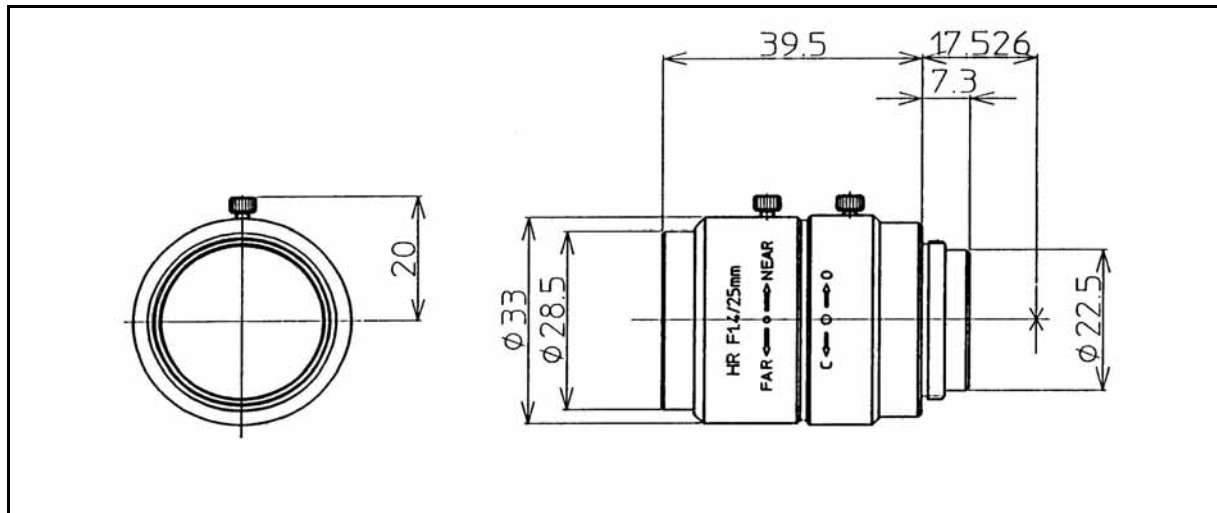

Image Format:	2/3-inch
Focal Length:	25mm
Relative Aperture:	F = 1: 1.4
Iris Range:	1.4 - 16
Angular Field of View:	Horizontal: 19.6°
	Vertical: 14.8°
Resolution:	Center : 100 lp/mm
	Corner : 80 lp/mm
Distortion:	on 2/3" sensor : -0.04%
	on 1/2" sensor :
MOD (Minimum Object Distance):	0.2m
Exit Pupil:	-80.0mm
Back Focus:	11.1mm in air
Flange Back:	17.526mm
Operation:	Focus: Manual with lock screw
	Iris: Manual with lock screw
Lens Mount:	C-Mount Type
Filter Screw:	27mm, P = 0.5
Dimensions:	φ33 x 39.5mm
Weight:	89g
Operating Temperature:	-10 ~ +45°C

Note : Angular field of view (H x V) is captured on the 2/3-inch image sensor at MOD.